

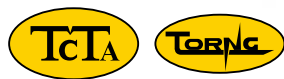

Insisting On Quality  
Outstanding R & D

---

**2018**



**宗伯實業有限公司**  
**TORNG INDUSTRIAL CO., LTD.**



本公司榮獲國家經濟部 103 年度  
協助傳統產業技術專案



## 宗伯堅持品質

宗伯實業有限公司專業生產各種機器配件，電動工具與倒角機。歷經多年來在技術創新與嚴格品質控管的努力下，宗伯產品深受國內外客戶的肯定與長期支持。堅持品質是宗伯公司的一貫傳統。每一項產品在製造過程中的每個階段，我們都以最嚴格的品質標準為依據，力求產品品質的完美，以因應客戶的嚴格要求。

## 卓越研發能力

不斷追求技術創新突破，是宗伯公司自從創立以來的一貫信念。多年來，我們在技術創新方面已投入了無數的心血與資金，在研發方面已獲得許多顯著的成果，有多項產品已榮獲專利。但是，我們絕不以現有的技術成就感到絲毫自滿。放眼未來，我們仍然持續不斷改良現有產品，以及開發新產品。並以獨特的產品特性，提供客戶更優質的產品性能。

## TORNG Insists On Quality

**TORNG** Industrial Co., Ltd, is a specialist in design and manufacturing of a wide range of machine accessories, power tools and chamfering machines.

Through years of efforts in technological innovation and rigorous quality control, **TORNG** products have been recognized and long-term supported by customers in domestic and overseas. Insisting on quality is a tradition at **TORNG**. Rigorous quality control is conducted at each stage throughout the manufacturing processes. What we do is to ensure the excellence of our products, that fully meet customers' rigorous requirements.

## Outstanding R&D Capability

Constantly pursuing technological innovation and breakthrough has been TORNG's unwavering philosophy since the company was established. Over the years, we have spent great efforts and capital in technological innovations, and have obtained brilliant achievements. However, we are never satisfied with the current achievement. Look to future, we will constantly improve our existed products, and develop new products. We are dedicated to provide special features of products with the superior performance for our customers.





## 目錄 CONTENTS

---

公司簡介	01-02	COMPANY PROFILE
刀具設定儀	04-06	TOOL PRESETTER
刀具調準器	06	TOOL ADJUSTER
鎖刀座系列	07-14	TOOL HOLDER LOCKING DEVICE
主軸清潔棒系列	15-17	TAPER WIPER
陶瓷尋邊器	18	EDGE FINDER
螺栓拉頭系列	19-20	PULL STUD
Z 軸設定器	21-22	Z-AXIS SET POINT STATION
倒角機系列	23-25	CHAMFERING MACHINE
磁性卡尺座	26	MAGNETIC VERNIER CALIPERS STAND
百分錶用陶瓷平面測頭	26	CERAMIC MEASURED FOR DIAL INDICATOR
手提倒角機	27-28	HAND CHAMFERING TOOLS
冷空氣產生器	29-30	AIR COOLER
切削冷卻噴霧器系列	31-33	MULTI-FUNCTION MIST COOLANT SYSTEM
筒夾放置架	34	COLLET RACK
工件定位器	35	WORK STOP TOOL
空油壓床	36	HYDRAULIC PRESS MACHINE
強力型換刀裝置	37-38	AIR POWER DRAWBAR /ELECTRIC POWER DRAWBAR
擋屑板	39	UNIVERSAL CHIP-SHIELDS
工業用 吸塵、吸水機	39	INDUSTRIAL WET / DRY VACUUM CLEANERS
工作台自動進給器	40	POWER TABLE FEEDS
伺服器工作台自動進給器	40	SERVO POWER TABLE FEEDS
攜帶型放電加工機	41-42	PORTABLE E.D.M.

## TP-4040HLA

### 光學尺 LINEAR SCALE

#### 標準配件：

- 光學尺
- 校正棒
- 百分表 x 2
- 防塵套
- 空壓鎖住刀桿

#### Standard Accessories:

- Linear Scale
- Test bar
- Dial Gauge x 2
- Dust Prevention Cover
- Toolbar is Locked by Pneumatic

## TP-4040HEA

### 液晶顯示尺 Electric Digital Scale

#### 標準配件：

- 液晶顯示尺
- 校正棒
- 百分表 x 2
- 防塵套
- 空壓鎖住刀桿

#### Standard Accessories:

- Electric Digital Scale
- Test bar
- Dial Gauge x2
- Dust Prevention Cover
- Toolbar is Locked by Pneumatic



#### 特點：

- 刀具設定儀主要為 CNC 立式、臥式切削加工機、綜合加工機、塘床、銑床等自動化機械、刀具檢測而設計，以節省刀具設定之時間。
- 可用來檢測刀具、真圓度、直角度、刀片位置，等工作。
- 本機主軸可利用 BT50#、BT40#、BT30# 之不同規格之刀桿檢測。
- 本機所有鑄件皆經過正常化處理、不易變型，確保其精密度。

#### Features:

- The tool presetter is suitable for tool measuring for various machine tools, such as CNC vertical machining center, CNC horizontal machining center, machining center, boring machine and milling machine etc. It greatly saves tool setting time.
- Suitable for measuring tool circularity, perpendicularity and insert position.
- Spindles of BT#50, BT#40 and BT#30 are available to change
- for fitting different specification tools.
- All casting parts of the machine are normalized to ensure deformation free and high accuracy.

### 規格表 Specification

型號 Model No.	行程 Travel	精密度 Graduation	尺寸 Machine size LxWxH	重量 Weight
TP-4040HLA	D: 400mm, L: 400mm	X-axis: 0.01 mm Z-axis: 0.01 mm	930x760x1050mm	100 kg
TP-4040HEA	D: 400mm, L: 400mm	X-axis: 0.01 mm Z-axis: 0.01 mm	930x760x1050mm	100 kg

## TP-4040HL

### 光學尺 LINEAR SCALE

#### 標準配件：

- Z 軸採用精密線性滑軌，耐磨性高，可保長久性的精度。
- X、Z 軸採光學尺裝置，顯示測量數字。
- X 軸研磨處理，精密度高。
- X、Z 軸快速螺桿設計，可做較快位移。

#### Features:

- Z-axis is mounted with precision linear guide for maximum wear-resistance and long-term accuracy.
- X, Z-axis are equipped with linear scales for displaying measured data.
- X-axis is precision ground for high accuracy.
- X, Z-axis are equipped with high speed screws, allowing for fast displacement.

#### 標準配件：

- 光學尺
- 校正棒
- 百分表 × 2
- 防塵套

#### Standard Accessories:

- Linear Scale
- Test bar
- Dial Gauge x 2
- Dust Prevention Cover



## TP-4040HE

### 液晶顯示尺 Electric Digital Scale

#### 標準配件：

- Z 軸採用精密線性滑軌，耐磨性高，可保長久性的精度。
- X、Z 軸採用液晶顯示裝置顯示測量數字。
- X 軸研磨處理，精密度高。
- X、Z 軸快速螺桿設計，可做較快位移。

#### Features:

- Z-axis is mounted with precision linear guide for maximum wear-resistance and long-term accuracy.
- X, Z-axis are equipped with electric digital scale to display measured data.
- X-axis is precision ground for high accuracy.
- X, Z-axis are equipped with high speed screws, allowing for fast displacement.

#### 標準配件：

- 液晶顯示尺
- 校正棒
- 百分表 × 2
- 防塵套

#### Standard Accessories:



- Electric Digital Scale
- Test bar
- Dial Gauge x2
- Dust Prevention Cover

### 規格表 Specification

型號 Model No.	行程 Travel	精密度 Graduation	尺寸 Machine size LxWxH	重量 Weight
TP-4040HL	D: 400mm, L: 400mm	X-axis: 0.01 mm Z-axis: 0.01 mm	930x760x1050mm	96 kg
TP-4040HE	D: 400mm, L: 400mm	X-axis: 0.01 mm Z-axis: 0.01 mm	930x760x1050mm	92 kg

# 刀具設定儀 TOOL PRESETTER

## 特別配件規格表 Specification list

					
型號 Model No.	TP-C	TSB-50-250L		ISO50-TSA40	ISO50-TSA30
重量 Weight	42 kg	5.4 kg	4.1 kg	1.7 kg	
尺寸 Size	76x50x60 cm	47.5x11x9.5 cm	47.5x11x9.5 cm		

# 刀具調準器 TOOL ADJUSTER

### 特點：

- 3D 快速測量校正。
- 刀具檢測。
- 搪孔刀具機上調整量測。
- 機上尺寸量測。
- 可使用百分表或千分表。

### Features:

- Quick 3D measurement correction.
- Tool testing.
- Borer adjustment and measurement.
- Dimension measurement.
- Dial gauge can be used.



TA-80

### 使用範例 Use example：



- 3D 校正
- 3D Correction



- 搪孔調整量測
- Borer adjustment and measurement.



- 垂直校正
- Vertical adjustment.

## *LDA TYPE*

### 特點：

- 後拉式刀桿可使用
- 可分迴轉角度為 90°、45°、180°。

### Features:

- Pull type tool is also suitable.
- The rotation angles are as follows : 90°, 45°, 180°.



# 迴轉型鎖刀座系列 ROTATION TYPE TOOL HOLDER LOCKING DEVICE

## BT

### 特點：

- 後拉式刀桿可使用
- 可分迴轉角度為 95°、45°、180°。

### Features:

- Pull type tool is also suitable.
- The rotation angles are as follows : 95°, 45°, 180°.

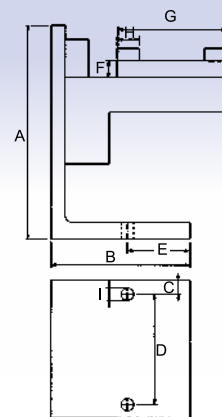

### 規格表 Specification

型號 Model No.	型式 Type	A	B	C	D	E	F	G	H	I	淨重 N.W.	毛重 G.W.	裝箱尺寸 Shipment Size
LDA-BT30	BT30	154.5	100	10	80	45	12	78	22.5	9	5.3 kg	5.5 kg	28x11.5x17cm
LDA-BT40	BT40	154.5	100	10	80	45	12	78	16	9	5.3 kg	5.5 kg	28x11.5x17cm

## HSK

### 特點：

- 後拉式刀桿可使用
- 可分迴轉角度為 95°、45°、180°。

### Features:

- Pull type tool is also suitable.
- The rotation angles are as follows : 95°, 45°, 180°.

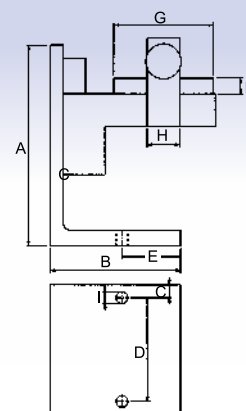

### 規格表 Specification

型號 Model No.	型式 Type	A	B	C	D	E	F	G	H	I	淨重 N.W.	毛重 G.W.	裝箱尺寸 Shipment Size
LDA-HSK63A	HSK63A	154.5	100	10	80	45	12	76.5	25	9	5.5 kg	5.7 kg	28x11.5x17cm

# 迴轉型鎖刀座系列 ROTATION TYPE TOOL HOLDER LOCKING DEVICE

## LDA

### 特點：

- 後拉式刀桿可使用
- 可分迴轉角度為 95°、45°、180°。

### Features:

- Pull type tool is also suitable.
- The rotation angles are as follows : 95°, 45°, 180°.

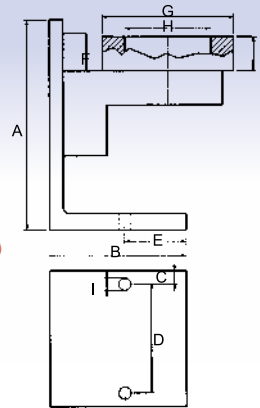

### 規格表 Specification

型號 Model No.	型式 Type	A	B	C	D	E	F	G	H	I	淨重 N.W.	毛重 G.W.	裝箱尺寸 Shipment Size
LDA-HSK63	HSK63	154.5	100	10	80	45	25	96.5	63	9	5.5 kg	5.7 kg	28x11.5x17cm
LDA-HSK50	HSK50	154.5	100	10	80	45	33	95	50	9	5.6 kg	5.8 kg	28x11.5x17cm
LDA-HSK40	HSK40	154.5	100	10	80	45	27	80	40	9	5.5 kg	5.7 kg	28x11.5x17cm
LDA-HSK32	HSK32	154.5	100	10	80	45	27	80	32	9	5.5 kg	5.7 kg	28x11.5x17cm
LDA-ISO20	ISO20	154.5	100	10	80	45	24	80	33	9	5.5 kg	5.7 kg	28x11.5x17cm
LDA-ISO25	ISO25	154.5	100	10	80	45	24	80	37	9	5.5 kg	5.7 kg	28x11.5x17cm
LDA-ISO30	ISO30	154.5	100	10	80	45	28	95	46	9	5.7 kg	5.9 kg	28x11.5x17cm
LDA-DIN30	DIN30	154.5	100	10	80	45	23	95	50	9	5.5 kg	5.7 kg	28x11.5x17cm

## LDAB

### 特點：

- 後拉式刀桿可使用
- 可分迴轉角度為 95°、45°、180°。

### Features:

- Pull type tool is also suitable.
- The rotation angles are as follows : 95°, 45°, 180°.

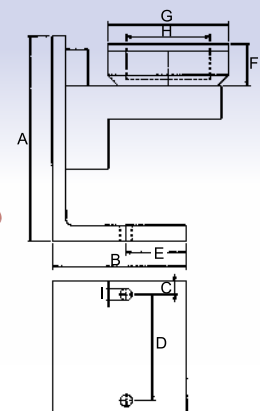

### 規格表 Specification

型號 Model No.	型式 Type	A	B	C	D	E	F	G	H	I	淨重 N.W.	毛重 G.W.	裝箱尺寸 Shipment Size
LDAB-HSK63	HSK63	154.5	100	10	80	45	31.5	90.5	63	9	5.8 kg	6.0 kg	28x11.5x17cm
LDAB-HSK50	HSK50	154.5	100	10	80	45	31.5	77.5	50	9	5.7 kg	5.9 kg	28x11.5x17cm

# 鎖刀座系列 TOOL HOLDER LOCKING DEVICE

## LDC

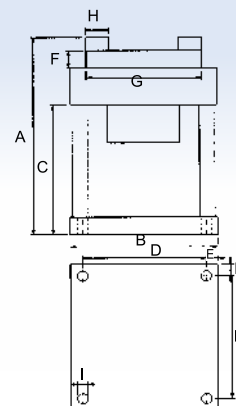

### 規格表 Specification

型號 Model No.	型式 Type	A	B	C	D	E	F	G	H	I	淨重 N.W.	毛重 G.W.	裝箱尺寸 Shipment Size
LDC-BT30	BT30	135	100	89	84	8	12	78	22.5	7	2.9 kg	3 kg	22x11.5x14cm
LDC-BT40	BT40	134	100	89	84	8	12	78	16	7	2.9 kg	3 kg	22x11.5x14cm
LDC-BT50	BT50	193	125	115	101	12	12	115	25	9	6.4 kg	6.8 kg	29.5x17x21cm

## LDC

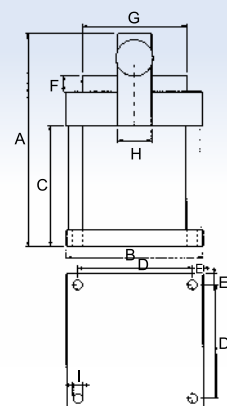

### 規格表 Specification

型號 Model No.	型式 Type	A	B	C	D	E	F	G	H	I	淨重 N.W.	毛重 G.W.	裝箱尺寸 Shipment Size
LDC-HSK63A	HSK63A	157	100	89	84	8	12	76.5	25	7	2.8 kg	3 kg	22x11.5x14cm
LDC-HSK100A	HSK100A	208	125	115	101	12	12	115	25	9	6.0 kg	7 kg	29.5x17x21cm

# 鎖刀座系列 TOOL HOLDER LOCKING DEVICE

## LDC

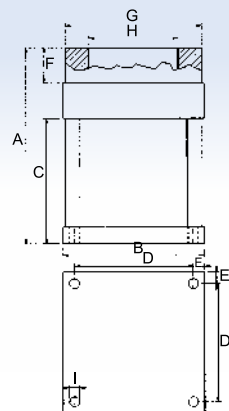

### 規格表 Specification

型號 Model No.	型式 Type	A	B	C	D	E	F	G	H	I	淨重 N.W.	毛重 G.W.	裝箱尺寸 Shipment Size
LDC-HSK63	HSK63	139		89	84	8	25	96.5	63	7	2.9 kg	3.1 kg	22x11.5x14cm
LDC-HSK50	HSK50	147	100	89	84	8	33	95	50	7	2.8 kg	3.0 kg	22x11.5x14cm
LDC-HSK40	HSK40	141	100	89	84	8	27	80	40	7	2.7 kg	2.9 kg	22x11.5x14cm
LDC-HSK32	HSK32	141	100	89	84	8	27	80	32	7	2.8 kg	3.0 kg	22x11.5x14cm
LDC-ISO20	ISO20	138	100	89	84	8	24	80	33	7	2.9 kg	3.0 kg	22x11.5x14cm
LDC-ISO25	ISO25	138	100	89	84	8	24	80	37	7	2.7 kg	2.9 kg	22x11.5x14cm
LDC-ISO30	ISO30	142	100	89	84	8	28	95	46	7	2.9 kg	3.0 kg	22x11.5x14cm
LDC-DIN30	DIN30	137	100	89	84	8	23	95	50	7	2.9 kg	3.1 kg	22x11.5x14cm

## LDCB

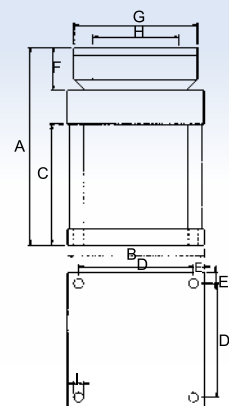

### 規格表 Specification

型號 Model No.	型式 Type	A	B	C	D	E	F	G	H	I	淨重 N.W.	毛重 G.W.	裝箱尺寸 Shipment Size
LDCB-HSK63	HSK63	145.5	100	89	84	8	31.5	96.5	63	7	3.0 kg	3.2 kg	22x11.5x14cm
LDCB-HSK50	HSK50	139.5	100	89	84	8	25.5	77.5	50	7	2.3 kg	2.5 kg	22x11.5x14cm

# 鎖刀座迴轉型系列 TOOL HOLDER ROTATION LOCKING DEVICE

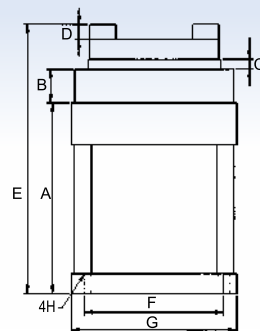

## 規格表 Specification

型號 Model No.	型式 Type	A	B	C	D	E	F	G	H	淨重 N.W.	毛重 G.W.	裝箱尺寸 Shipment Size
LDC-BT40R	BT40	114	20	6	9	161	84	100	7	3.1 kg	3.3 kg	22x11.5x14cm

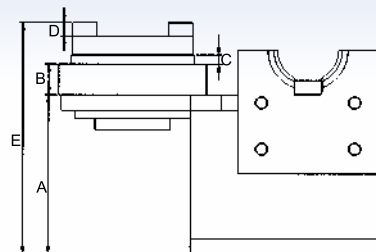

## 規格表 Specification

型號 Model No.	型式 Type	A	B	C	D	E	淨重 N.W.	毛重 G.W.	裝箱尺寸 Shipment Size
LD-BT40AR	BT-40	103	20	6	9	150	4.2 kg	4.4 kg	22x11.5x14cm

# 鎖刀座系列 TOOL HOLDER LOCKING DEVICE

## A TYPE

主體為鑄鋼  
CAST STEEL BODY

- 立式刀座為鋁製品。
- Vertical tool rest : aluminum.

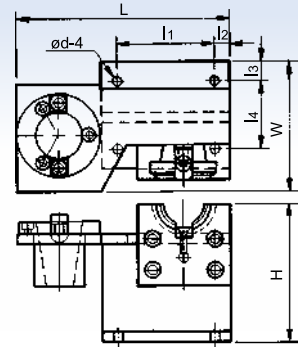

### 規格表 Specification

型號 Model No.	型式 Type	L	I <sub>1</sub>	I <sub>2</sub>	I <sub>3</sub>	I <sub>4</sub>	H	W	淨重 N.W.	毛重 G.W.	裝箱尺寸 Shipment Size
LD-BT30AF	BT30	210	95	10	15	67	130	100	2.8 kg	3 kg	22x11.5x14cm
LD-BT40AF	BT40	210	95	10	15	67	130	100	3.0 kg	3.2 kg	22x11.5x14cm
LD-DIN40AF	DIN40	210	95	10	15	67	130	100	3.0 kg	3.2 kg	22x11.5x14cm
LD-CAT40AF	CAT40	210	95	10	15	67	130	100	3.0 kg	3.2 kg	22x11.5x14cm

F : 本體為鑄鋼 body is steel

## A TYPE

主體為鑄鐵  
CAST IRON BODY

- 立式刀座為鋁製品。
- Vertical tool rest : aluminum.

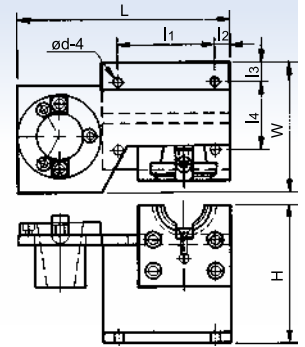

### 規格表 Specification

型號 Model No.	型式 Type	L	I <sub>1</sub>	I <sub>2</sub>	I <sub>3</sub>	I <sub>4</sub>	H	W	淨重 N.W.	毛重 G.W.	裝箱尺寸 Shipment Size
LD-BT30A	BT30	210	95	10	15	67	130	100	3.6 kg	3.7 kg	22x11.5x14cm
LD-BT40A	BT40	210	95	10	15	67	130	100	3.7 kg	3.9 kg	22x11.5x14cm
LD-BT50A	BT50	275	113	20	24	105	200	150	11 kg	11.4 kg	29.5x17x21cm
LD-DIN40A	DIN40	210	95	10	15	67	130	100	3.6 kg	3.8 kg	22x11.5x14cm
LD-DIN50A	DIN50	275	113	20	24	105	200	150	10.8 kg	11.2 kg	29.5x17x21cm
LD-CAT40A	CAT40	210	95	10	15	67	130	100	3.6 kg	3.8 kg	22x11.5x14cm
LD-CAT50A	CAT50	275	113	20	24	105	200	150	10.8 kg	11.2 kg	29.5x17x21cm

# 鎖刀座系列 TOOL HOLDER LOCKING DEVICE

## AP TYPE

主體為鑄鐵  
CAST IRON BODY

- 立式刀座為鋁製品。
- Vertical tool rest : aluminum.

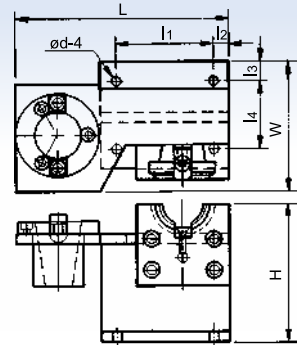

### 規格表 Specification

型號 Model No.	型式 Type	L	l <sub>1</sub>	l <sub>2</sub>	l <sub>3</sub>	l <sub>4</sub>	H	W	淨重 N.W.	毛重 G.W.	裝箱尺寸 Shipment Size
LD-BT30AP	BT30	210	95	10	15	67	130	100	3.8 kg	4 kg	22x11.5x14cm
LD-BT40AP	BT40	210	95	10	15	67	130	100	3.8 kg	4 kg	22x11.5x14cm
LD-BT50AP	BT50	275	113	20	24	105	200	150	11 kg	11.4 kg	29.5x17x21cm

## B TYPE

主體為鋁製品  
CAST ALUMINUM BODY

- 此型為立、臥兩用型。
- 不須分 BT, CAT, DIN 均可使用。
- Vertical and horizontal configuration.
- Applicable to BT, CAT, DIN tapers.

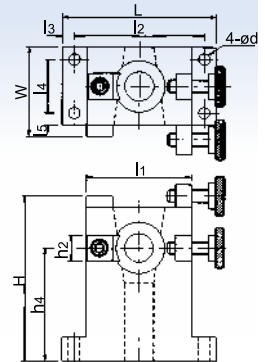

### 規格表 Specification

型號 Model No.	型式 Type	L	l <sub>1</sub>	l <sub>2</sub>	l <sub>3</sub>	l <sub>4</sub>	H	W	淨重 N.W.	毛重 G.W.	裝箱尺寸 Shipment Size
LD-30B	30	95	65	80	7.5	33	100	58	0.9 kg	1 kg	13x10x16cm
LD-40B	40	118	77	99	9.2	44	130	75	1.6 kg	1.7 kg	13x10x16cm
LD-50B	50	170	92	110	12	53	185	115	5.1 kg	5.4 kg	29.5x17x21cm

## 棉質清潔棒系列 NON-WOVEN FABRIC SPINDLE TAPER WIPER

### BT TYPE

**特點：**

清潔棒的清潔片由不織布製成，可清理主軸內部，不傷主軸，延長主軸使用壽命。

**Features:**

Cleaning ships of taper wiper is made of non-woven fabric. It can clean inside slides of spindles to prevent static electricity and to extend spindles and tapers using time.



#### 規格表 Specification

型號 Model No.	斜度 Taper	淨重 N.W.	毛重 G.W.	裝箱尺寸 Shipment Size	備註 Remarks
W-30	#30	0.06 kg	0.08 kg	41x29.5x20cm	
W-40	#40	0.07 kg	0.10 kg	41x29.5x20cm	
W-50	#50	0.16 kg	0.2 kg	41x29.5x20cm	

## 羊皮清潔棒系列 NON-WOVEN LAMBSKIN SPINDLE TAPER WIPER

### BT TYPE

**特點：**

清潔棒的清潔片由小羊皮製成，可清理主軸內部，不傷主軸，不產生靜電，延長主軸使用壽命。

**Features:**

Cleaning ships of taper wiper is made of lambskin. It can clean inside slides of spindles to prevent static electricity and to extend spindles and tapers using time.



#### 規格表 Specification

型號 Model No.	斜度 Taper	淨重 N.W.	毛重 G.W.	裝箱尺寸 Shipment Size	備註 Remarks
W-30P	#30	0.06 kg	0.08 kg	41x29.5x20cm	
W-40P	#40	0.07 kg	0.10 kg	41x29.5x20cm	
W-50P	#50	0.16 kg	0.2 kg	41x29.5x20cm	

## 清潔棒系列 TAPER WIPER

**HSK TYPE**



W-HSK100H

W-HSK63H

W-HSK50H

W-HSK40A

### 規格表 Specification

型號 Model No.	型式 Type	淨重 N.W.	毛重 G.W.	裝箱尺寸 Shipment Size	備註 Remarks
W-HSK40A	HSK40	0.08 kg	0.1 kg	41x29.5x20cm	
W-HSK50H	HSK50 / HSK63F	0.08 kg	0.12 kg	41x29.5x20cm	
W-HSK63H	HSK63	0.1 kg	0.13 kg	41x29.5x20cm	
W-HSK100H	HSK100	0.5 kg	0.7 kg	41x29.5x20cm	

## 小型清潔棒 TAPER WIPER



### 規格表 Specification

型號 Model No.	斜度 Taper	淨重 N.W.	毛重 G.W.	備註 Remarks
W-10	1/10	0.02 kg	0.02 kg	

# 毛刷清潔棒系列 BRUSH TAPER WIPER



規格表 Specification

型號 Model No.	外徑 Diameter	淨重 N.W.	備註 Remarks
IBBW-8	8.1 m/m	20 g	
IBBW-10	10.1 m/m	22 g	
IBBW-12	12.1 m/m	23 g	
IBBW-16	16.1 m/m	23 g	
IBBW-20	20.1 m/m	25 g	
IBBW-25	25.1 m/m	25 g	
IBBW-32	32.1 m/m	26 g	

規格表 Specification

型號 Model No.	外徑 Diameter	淨重 N.W.	備註 Remarks
IBBW-5/16	8.1 m/m	20 g	
IBBW-3/8	9.7 m/m	21 g	
IBBW-3/32	10.1 m/m	22 g	
IBBW-7/16	11.3 m/m	23 g	
IBBW-15/32	12.1 m/m	23 g	
IBBW-1/2	13.1 m/m	23 g	

規格表 Specification

型號 Model No.	長度 Length	淨重 N.W.
HNT-100	100	56 g
HNT-150	150	45 g



規格表 Specification

型號 Model No.	外徑 Diameter	備註 Remarks
IBBW-3	3.1 m/m	
IBBW-4	4.1 m/m	
IBBW-5	5.1 m/m	
IBBW-6	6.1 m/m	

規格表 Specification

型號 Model No.	外徑 Diameter	備註 Remarks
IBBW-1/8	3.1 m/m	
IBBW-5/32	4.1 m/m	
IBBW-3/16	5.1 m/m	
IBBW-1/4	6.5 m/m	

## 陶瓷尋邊器 CERAMIC EDGE FINDER

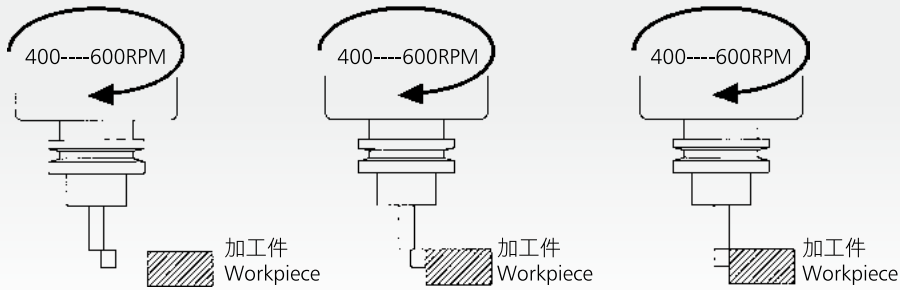

- 主軸迴轉後尋邊器慢慢靠近加工物
- 側定面慢慢移 動至中心後急速偏出點就是測定值
- 移送測定端子 (10mm) 的一半 (5mm) 即主軸與加工面之端面是同一面
- After spindle rotate, edge tool approach work piece slowly.
- After side set face moving slowly to center, rapid excursion point is the measured data.
- Half of the transferred measured terminal is same with the terminal of spindle.



## 機械式尋邊器 MECHANICAL EDGE FINDER

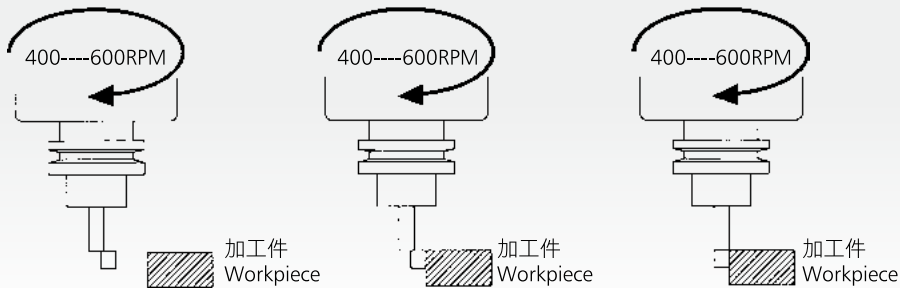

- 主軸迴轉後尋邊器慢慢靠近加工物
- 側定面慢慢移 動至中心後急速偏出點就是測定值
- 移送測定端子 (10mm) 的一半 (5mm) 即主軸與加工面之端面是同一面
- After spindle rotate, edge tool approach work piece slowly.
- After side set face moving slowly to center, rapid excursion point is the measured data.
- Half of the transferred measured terminal is same with the terminal of spindle.



## 螺栓拉頭 ( 研磨級 ) PULL STUD (GRINDING THREAD)

材質為白十字鋼  
MATERIAL : SNCM 21

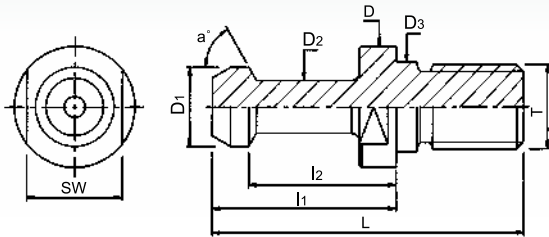

PS-BT30



PS-BT40



PS-BT50

## 螺栓拉頭 ( 研磨級 ) PULL STUD (GRINDING THREAD)

### 規格表 Specification

型號 Model No.	型式 Type	a°	L	L <sub>1</sub>	L <sub>2</sub>	D	D <sub>1</sub>	D <sub>2</sub>	D <sub>3</sub>	M	重量 Weight
PS-BT30-45°N	BT30x45°	45	43	23	18	16.5	11	7	12.5	M12	0.04kg
PS-BT30-60°N	BT30x60°	60	43	23	18	16.5	11	7	12.5	M12	0.04kg
PS-BT30-90°N	BT30x90°	90	43	23	18	16.5	11	7	12.5	M12	0.04kg
PS-BT40-45°N	BT40x45°	45	60	35	28	23	15	10	17	M16	0.10kg
PS-BT40-60°N	BT40x60°	60	60	35	28	23	15	10	17	M16	0.10kg
PS-BT40-90°N	BT40x90°	90	60	35	28	23	15	10	17	M16	0.10kg
PS-BT50-45°N	BT50x45°	45	85	45	35	38	23	17	25	M24	0.30kg
PS-BT50-60°N	BT50x60°	60	85	45	35	38	23	17	25	M24	0.30kg
PS-BT50-90°N	BT50x90°	90	85	45	35	38	23	17	25	M24	0.30kg

## 給水型螺栓拉頭 PULL STUD (COOLANT TYPE)

### 規格表 Specification

型號 Model No.	型式 Type	a°	L	L <sub>1</sub>	L <sub>2</sub>	D	D <sub>1</sub>	D <sub>2</sub>	D <sub>3</sub>	M	重量 Weight
PS-BT40-45°	BT40x45°	45	60	35	28	23	15	10	17	M16	0.08kg
PS-BT40-60°	BT40x60°	60	60	35	28	23	15	10	17	M16	0.08kg
PS-BT40-90°	BT40x90°	90	60	35	28	23	15	10	17	M16	0.08kg
PS-BT50-45°	BT50x45°	45	85	45	35	38	23	17	25	M24	0.28kg
PS-BT50-60°	BT50x60°	60	85	45	35	38	23	17	25	M24	0.28kg
PS-BT50-90°	BT50x90°	90	85	45	35	38	23	17	25	M24	0.28kg

## 螺栓拉頭 ( 研磨級 ) PULL STUD ( GRINDING THREAD )

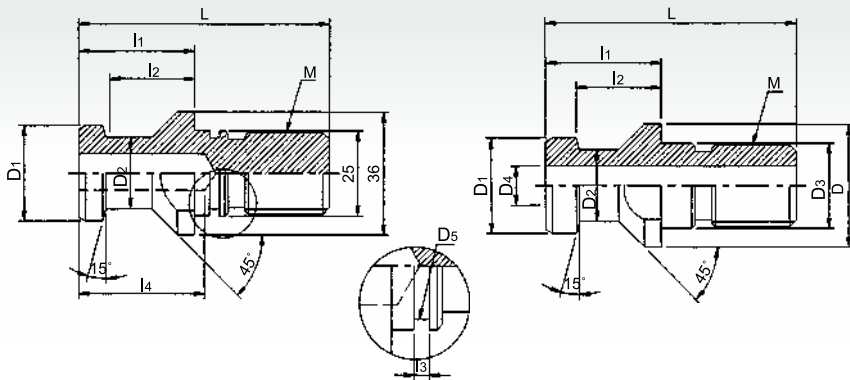

### 規格表 Specification

型號 Model No.	型式 Type	L	L <sub>1</sub>	L <sub>2</sub>	L <sub>3</sub>	L <sub>4</sub>	D	D <sub>1</sub>	D <sub>2</sub>	D <sub>3</sub>	D <sub>4</sub>	M	重量 Weight
PS-DAT30NA	DAT30-A	44	24	19	-	-	17	13	9	13	-	M12	0.03kg
PS-DAT40NA	DAT40-A	54	26	20	-	-	23	19	14	17	7	M16	0.09kg
PS-DAT50NA	DAT50-A	74	34	25	-	-	36	28	21	25	11.5	M24	0.25kg
PS-DAT30N	DAT30-A	44	24	19	1.4	-	17	13	9	13	-	M12	0.03kg
PS-DAT40N	DAT40-A	54	26	20	1.9	27	23	19	14	17	7	M16	0.09kg
PS-DAT50N	DAT50-A	74	34	25	3	37	36	28	21	25	11.5	M24	0.25kg

## 螺栓拉頭 ( 研磨級 ) PULL STUD ( GRINDING THREAD )

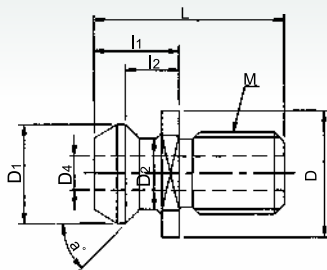

### 規格表 Specification

型號 Model No.	型式 Type	a°	L	L <sub>1</sub>	L <sub>2</sub>	D	D <sub>1</sub>	D <sub>2</sub>	D <sub>3</sub>	M	重量 Weight
PS-CAT40-45*N	CAT40	45	38.1	16.2	11.2	23.8	18.8	12.4	7.1	5/8"	
PS-CAT50-45*N	CAT50	45	58.4	25.4	17.8	36	28.9	20.8	11.8	1"	

# Z 軸設定器 Z-AXIS SET POINT STATION

( 微小刀具專用 ) ( FOR TINY TOOL USE )

★ 最小刀具測定 0.1m/m

★ Minimum measurement of cutting tool : 0.1m/m

## 特點：

- 刀具最小測定為 0.1m/m 左右。
- 測量面為陶瓷，測量面不容易刮傷。
- 測錶內動式設計，測錶不會因碰撞而故障。
- 可分有磁性底座和無磁性底座可供選擇。
- 可分 50m/m 高及 100m/m 高可供選擇。
- 適用 CNC 中心切削機、銑床、雕刻機、CNC 車床、車床。
- 測量錶精度：0.01m/m。

## Features:

- Minimum measurement of cutting tool : 0.1m/m.
- Measurement side is ceramics and it is not easily to scratch.
- Measurement gauge is designed by inserting. Measurement gauge will not easily breakdown by crash.
- We have magnetic base and without magnetic base for your choice.
- We have 50m/m height and 100m/m height for your choice.
- Suitable for CNC machine center, milling machine, engraving machine, CNC lathe and lathe.
- The precision of measure gauge : 0.01m/m.



ZPM-50



ZPM-50P



ZPM-100P

## 規格表 Specification

型號 Model No.	刀具最小設定 Diameter of cutting tool least measurement	高度 Height	淨重 N.W.	毛重 G.W.	裝箱尺寸 Shipment Size
ZPM-50	0.1m/m	50m/m	0.5 kg	0.6 kg	13.5x10.5x8cm
ZPM-50P	0.1m/m	50m/m	0.5 kg	0.62 kg	13.5x10.5x8cm
ZPM-100P	0.1m/m	100m/m	1.4 kg	1.5 kg	13.5x10.5x8cm

# 不銹鋼 Z 軸設定器 STAINLESS Z-AXIS SET POINT STATION

## 特點：

- 測量面圓徑  $\varnothing 38\text{m/m}$
- 可分有磁性底座和無磁性底座可供選擇。
- 可分 50m/m 高及 100m/m 高可供選擇。
- 適用 CNC 中心切削機、銑床、CNC 車床、車床。
- 測量錶精度： $0.01\text{m/m}$ 。

## Features:

- Measured part's circulation diameter 38m/m.
- We have magnetic base and without magnetic base for your choice.
- We have 50m/m height and 100m/m height for your choice.
- Suitable for CNC machine center, milling machine, CNC lathe and lathe.
- The precision of measure gauge : 0.01m/m.



ZP-50



ZP-50P



ZP-100P

## 規格表 Specification

型號 Model No.	刀具最小設定 Diameter of cutting tool least measurement	高度 Height	淨重 N.W.	毛重 G.W.	裝箱尺寸 Shipment Size
ZPS-50	1m/m	50m/m	0.6 kg	0.7 kg	13.5x10.5x8cm
ZPS-50P	1m/m	50m/m	0.6 kg	0.7 kg	13.5x10.5x8cm
ZPS-100P	1m/m	100m/m	1.48 kg	1.78 kg	13.5x10.5x8cm

# 平面銑刀臥式倒角機

(角度可調式)

# CHAMFERING MACHINE

(ANGLE ROTATABLE FACE MILLING CUTTER TYPE)

## 特點：

- 採用面銑原理加工，倒角方式如同銑削。
- 適合材質：碳素鋼、合金鋼、鐵和鋁。
- 倒角後，它的表面較側銑式光滑。
- 倒角角度：45°
- 角度可旋轉

## Features:

- Working based on surface milling principles, the chamfering way is same as milling machine.
- Suitable for carbon steel, alloy steel, iron and aluminum.
- Its surface is smoother than side cutter type, after chamfering.
- Bevel angle:45\*
- Angle can be rotated.

本機使用刀片規格 SEKN 1203

Knife Specification SEKN 1203

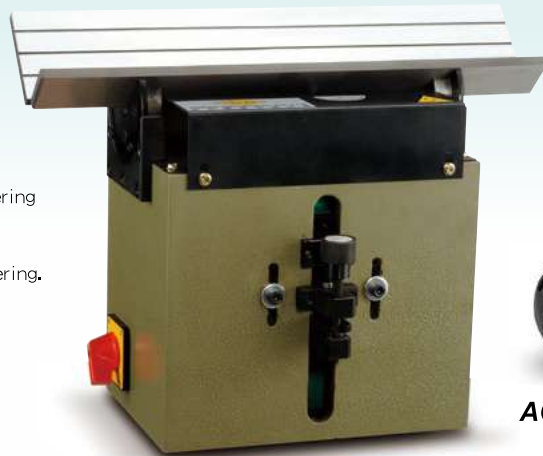

ACMC-500

## 規格表 Specification

型號 Model No.	倒角能力 Chamfering Capacity	迴轉速 Running Speed	電壓 Voltage	淨重 N.W.	毛重 G.W.	裝箱尺寸 Shipment Size	備註 Remarks
ACMC-500	0~3m/m	3600 R. P. M.	110/220/380V	28 kg	32 kg	53x42x41cm	

# 平面銑刀臥式倒角機

# CHAMFERING MACHINE

(FACE MILLING CUTTER TYPE)

## 特點：

- 採用面銑原理加工，倒角方式如同銑削。
- 適合材質：碳素鋼、合金鋼、鐵和鋁。
- 倒角後，它的表面較側銑式光滑。
- 倒角角度：45°

## Features:

- Working based on surface milling principles, the chamfering way is same as milling machine.
- Suitable for carbon steel, alloy steel, iron and aluminum.
- Its surface is smoother than side cutter type, after chamfering.
- Bevel angle:45\*

本機使用刀片規格 SEKN 1203

Knife Specification SEKN 1203



CMC-500N

## 規格表 Specification

型號 Model No.	倒角能力 Chamfering Capacity	迴轉速 Running Speed	電壓 Voltage	淨重 N.W.	毛重 G.W.	裝箱尺寸 Shipment Size	備註 Remarks
CMC-500N	0~3m/m	3600 R. P. M.	110/220/380V	29 kg	32 kg	53x42x41cm	

# 砂輪臥式倒角機 CHAMFERING MACHINE

(GRINDING WHEEL TYPE)

**特點：**

- 使用砂輪切削，熱處理後之工件也可輕易倒角。

**Features:**

- After heat treatment's workpieces also could easily chamfer by using grinding wheel type.

(本機使用砂輪機規格：

外徑 125x 內徑 31.75x 厚度 50m/m)

(Specification of the grinding wheel :  
external diameter 125xinternal diameter  
31.75xdepth 50m/m)



**CMW-500N**

**規格表 Specification**

型號 Model No.	倒角能力 Chamfering Capacity	迴轉速 Running Speed	電壓 Voltage	淨重 N.W.	毛重 G.W.	裝箱尺寸 Shipment Size	備註 Remarks
CMW-500N	0~3m/m	3600 R. P. M.	110/220/380V	29 kg	32 kg	53x42x41cm	

# 側銑刀臥式倒角機 CHAMFERING MACHINE

(SIDE CUTTER TYPE)

**特點：**

- 適合材質：碳素鋼、合金鋼、鐵和鋁。
- 角度可調整。

**Features:**

- Suitable for carbon steel, alloy steel, iron and aluminum.
- Angle can be adjusted.

本機使用刀片規格 SPKN 1203

Knife Specification SPKN 1203



**CMS-500**

**規格表 Specification**

型號 Model No.	倒角能力 Chamfering Capacity	迴轉速 Running Speed	電壓 Voltage	淨重 N.W.	毛重 G.W.	裝箱尺寸 Shipment Size	備註 Remarks
CMS-500	0~3m/m	3600 R. P. M.	110/220/380V	28 kg	31 kg	53x42x41cm	

# 砂布輪臥式倒角機

# CHAMFERING MACHINE

(SANDING WHEEL TYPE)

## 特點：

- 本機適用於工件的毛邊去除及倒角作業。
- 硬材質或熱處理後之工件都可輕易去除毛邊或倒角。
- 倒角後之工件不會產生毛邊或崩角問題，工件表面更光滑順暢。
- 操作簡易，安全性高。

## Features:

- Suitable for remove workpiece burrs and chamfering work.
- Hardened workpiece or heat treatment workpiece also could easily remove burrs or chamfer angles.
- It never grows burr and never skip off, after the burr removal and it will be much more smooth.
- Easy to operate and safety.

本機使用砂布輪規格：Ø100 x Ø16

Sanding Wheel Specification Ø100 x Ø16



CMS-320

## 規格表 Specification

型號 Model No.	倒角能力 Chamfering Capacity	迴轉速 Running Speed	電壓 Voltage	淨重 N.W.	毛重 G.W.	裝箱尺寸 Shipment Size	備註 Remarks
CMS-320	0~3m/m	3600 R. P. M.	110/220/380V	24 kg	27 kg	53x42x41cm	

# 磁性卡尺座 MAGNETIC VERNIER CALIPERS STAND

適用 6"-8" 卡尺。  
Applicable 6" to 8" caliper.

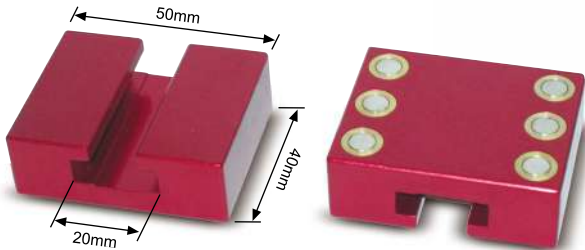
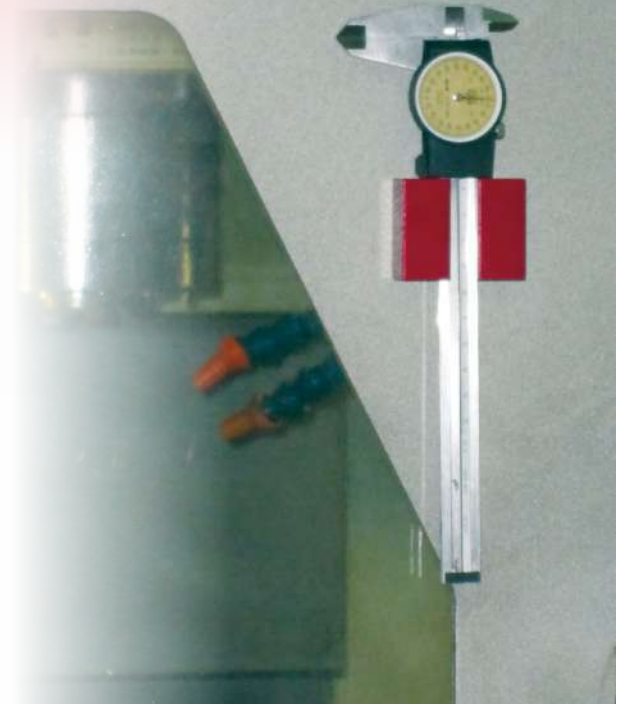

MVCS-6

# 百分錶用陶瓷平面測頭 CERAMIC MEASURED FOR DIAL INDICATOR

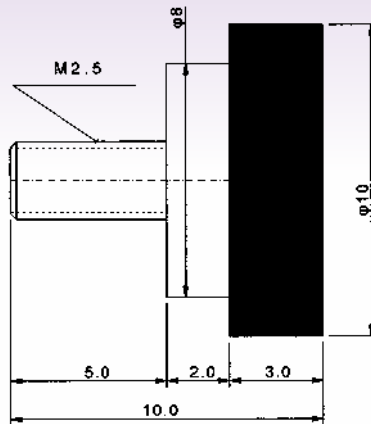
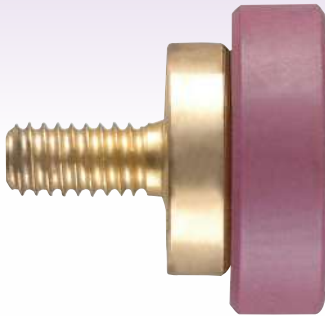

# 手提倒角機 HAND CHAMFERING TOOLS

## 多功能手提倒角機

## MULTI-FUNCTION HAND CHAMFERING TOOL

### 特點：

- 可倒角 0 ~ 2.5 m/m 之倒角。
- 為多功能設計，可倒小零件及大型工件。
- 可用薄型工件（3m/m 厚度以下）。
- 可用直角型工件倒角。
- 可用不規則形狀及圓弧形狀加工件使用。

### Features:

- The unit provides chamfering 0-2.5 m/m.
- Multi function design, Suitable for chamfering small workpiece or large workpiece.
- Suitable for chamfering the thin workpiece (within 3m/m).
- Suitable for chamfering vertical workpiece.
- Suitable for chamfering irregular shape and arc workpiece.



**MFHCT-03HG**

### 規格表 Specification

型號 Model No.	倒角能力 Chamfering Capacity	迴轉速 Running Speed	電壓 Voltage	淨重 N.W.	毛重 G.W.	裝箱尺寸 Shipment Size	刀片規格 Inserts Specification	備註 Remarks
MFHCT-03HG	0~2.5m/m	12000 R. P. M.	220V/110V	2.6 kg	2.8 kg	36x13.5x12.5cm	SPMW 090308	進口主機 Import body

## 直角式手提倒角機

## VERTICAL TYPE HAND CHAMFERING TOOL

### 特點：

- 本機可倒 0 ~ 3 m/m，C 角 R 角及直線之倒角。
- 本機適用於不易搬動之重型加工件倒角。
- 操作簡單、方便、省時。
- 適用於大型工件、各型模具、機械零件及鋼鐵，鑄鐵製造之零件倒角。
- 適用直角型加工件之倒角。

### Features:

- Suitable for chamfering angle C, angle R and straight line.
- The unit provides chamfering 0-3 m/m.
- Suitable for heavy workpiece. Easy operation, convenient and save time.
- Suitable for chamfering of large workpieces molds, steels and component's chamfered when processing of iron casting.
- Suitable for vertical workpiece.



**VHCT-03HG**

### 規格表 Specification

型號 Model No.	倒角能力 Chamfering Capacity	迴轉速 Running Speed	電壓 Voltage	淨重 N.W.	毛重 G.W.	裝箱尺寸 Shipment Size	刀片規格 Inserts Specification	備註 Remarks
VHCT-03HG	0~3m/m	12000 R. P. M.	220V/110V	2.5 kg	2.8 kg	36x13.5x12.5cm	SPMW 090308	進口主機 Import body

# 手提倒角機 HAND CHAMFERING TOOLS

## 不規則式手提倒角機 IRREGULAR TYPE HAND CHAMFERING TOOL

### 特點：

- 本機可倒 0 ~ 3 m/m C 角及曲線之倒角。
- 適用於不易搬動之重型加工件倒角。
- 操作簡單、方便、省時。
- 適用於大型工件、模具、機械零件及鋼鐵、鑄造之零件倒角。
- 適用於不規則形狀及圓弧曲線之倒角。

### Features:

- Suitable for chamfering angle C and curve.
- The unit provides chamfering 0-3 m/m.
- Suitable for heavy workpiece.
- Easy operation, convenient and save time.
- Suitable for chamfering of large workpieces molds, steels and component's chamfered when processing of iron casting.
- Suitable for chamfering irregular shape and external curve.



**IHCT-03HG**

### 規格表 Specification

型號 Model No.	倒角能力 Chamfering Capacity	迴轉速 Running Speed	電壓 Voltage	淨重 N.W.	毛重 G.W.	裝箱尺寸 Shipment Size	刀片規格 Inserts Specification	備註 Remarks
IHCT-03HG	0~3m/m	12000 R. P. M.	220V/110V	2.2 kg	2.4 kg	36x13.5x12.5cm	SPMW 090308	進口主機 Import body

## 氣動式手提倒角機 AIR TYPE HAND CHAMFERING TOOL

### 特點：

- 氣動倒角機無須考慮電壓及插座問題，只需使用空氣壓縮機產生之風壓 (5HP 以上) 即可使用。

### Features:

- No consideration of voltage and plug, the unit operates by air pressure from compressor (up 5HP).



**AHCT-03**

### 規格表 Specification

型號 Model No.	倒角能力 Chamfering Capacity	迴轉速 Running Speed	風壓 Voltage	淨重 N.W.	毛重 G.W.	裝箱尺寸 Shipment Size	刀片規格 Inserts Specification	備註 Remarks
AHCT-03	0~3m/m	12000 R. P. M.	90psi/63kg/cm2	2.5 kg	2.9 kg	36x13.5x12.5cm	SPMW 090308	

# 冷空氣產生器 AIR COOLER

## 特點：

- 使用冷空氣於切削上做乾式切削
- 使用冷空氣作用專用模具冷卻及清潔工作
- 使用空壓機之空氣可使噴出空氣變為冰冷空氣
- 空壓機出口空氣需無水份
- 空壓機最小為 2HP 以上（馬力越大產生的冷空氣愈冷）
- 產生之冷空氣最低可零下 40°C (0°C -{-40- {40°C )
- 可使用於鑽床、床、車床、中心切削機、專用切削機及模具冷卻

## Features:

- Use cold air for dry finishing cutting in each cutting action.
- Use cold air particularly for mold cooling and cleaning task.
- The air coming from air compressor is able to cause itself to be cold air through the system.
- Moisture is forbidden against the air from the output of the air compressor.
- The horse power of the air compressor should be more than 2HP at least. (More HP will affect colder air)
- The lowest temperature degree of the cold air made will be 40°C below zero (0°C -{-40- {40°C )
- Useful in drilling, milling machine, machine center, cutting machine center, and mold cooling.

## AC-30

本產品可做任何方式的組裝

The item can be of various ways of assembly.



## AC-30A

本產品配合磁性座可用於任何可吸附之機械上

Combined with magnetic base, it can be attached on either one of machines mentioned above.

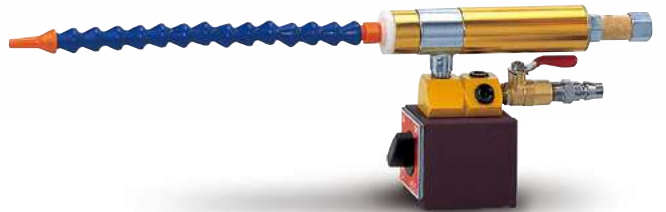

## AC-30B-80

## AC-30B-100

- 本產品配合萬向磁性座，可用於任何可吸附之機械上做任何角度之調整
- 本產品磁力可分為 80 公斤或 100 公斤可供選

- Combined with universal magnetic base, it will be useful in various angle adjustments after attached on either one of machines mentioned above.
- The magnetic power of it is optional either 80 or 100 kilograms.



# 冷空氣產生器 AIR COOLER

## AC-30C

本產品可固定於任何機械上做任何角度的調整  
It will be useful in various angle adjustments after attached on either one of machines mentioned above.



## AC-30D

本產品為專用機中心切削機使用  
It is particularly useful in machining center.

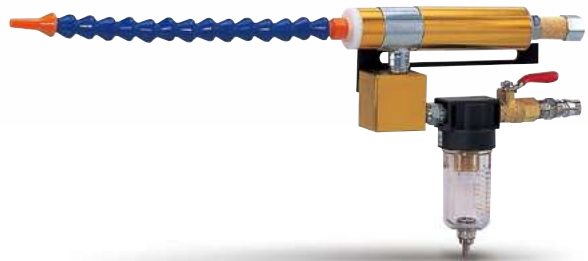

## AC-30E

本產品為泛用型可固定於機械上使用  
This product can be mounted on various machines.

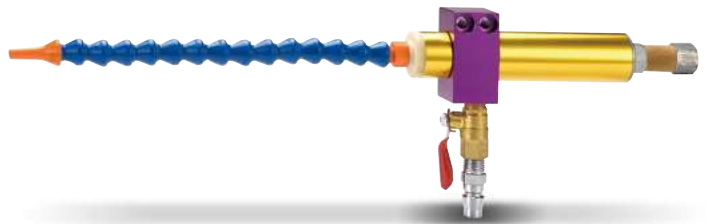

另可配用以下軟管可供選擇：  
CHOICE OF FLEXIBLE TUBES :

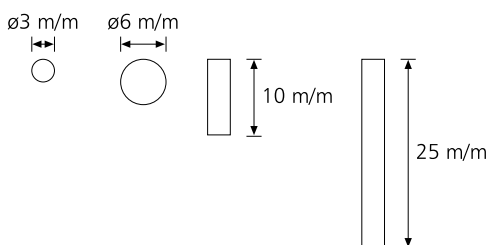

# 多功能切削冷卻噴霧器

# MULTI-FUNCTION MIST COOLANT SYSTEM

## 特點：

- 多功能切削噴霧器可同時提供冷卻、潤滑及除屑功能。
- 可大幅提昇切削性、加工速度及延長刀具使用壽命。節省加工時間，降低加工成本。
- 確保優異加工品質及切削性能。
- 對堅韌之合金鋼材加工，此噴霧器為精細之表面加工效果輔以一臂之力。

## Features:

- It can be operated at the same time for cooling, lubrication, blows the metal chips.
- It was designed not only for improves machinability, cutting speed, but also for extend tool life to save your working time and cost.
- Ensure better processing quality and high performance of your tool.
- For tough and tensile alloy steel workpiece, this product could improve better processing quality.

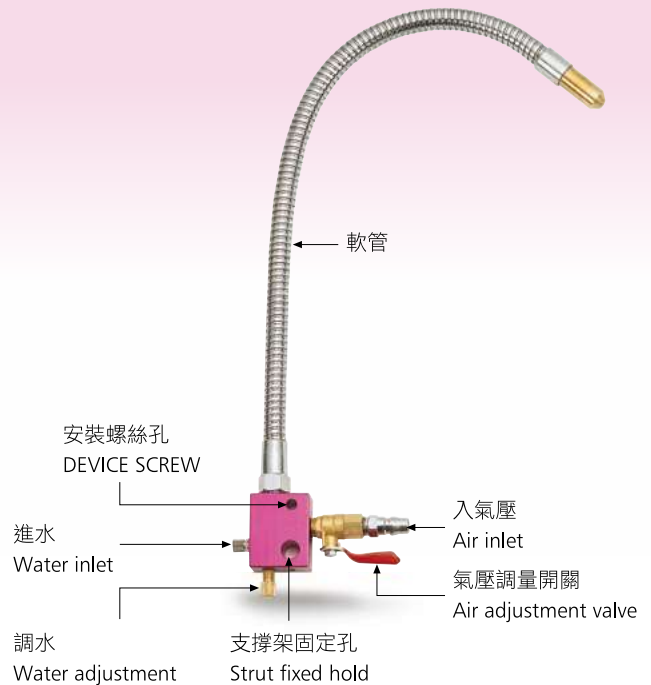

## 特點：

- 適用於各型工作母機及刀具冷卻。
- 可加特別配件使用於鑽床或其他工作母機使用。
- 附兩米水管 + 濾水接頭。

## Features:

- Suitable for various machine tool and cutting tools cooling.
- An additional accessories can be used in drilling or any other machine tool.
- Attach with 2M water pipe, filter joint.

噴霧器本體顏色以公司出貨為主

The color of sprayer body is subject to the actual shipment upon delivery.



## 規格表 Specification

型號 Model No.	淨重 N.W.	毛重 G.W.	裝箱尺寸 Shipment Size	備註 Remarks
TCT-250	0.55 kg	0.75 kg	41x29.5x20cm	10 支 / 箱 10pcs/CTN
TCT-500	0.70 kg	0.9 kg	41x29.5x20cm	10 支 / 箱 10pcs/CTN

# 多功能切削冷卻噴霧器

# MULTI-FUNCTION MIST COOLANT SYSTEM

**特點：**

- 可作移動式使用。

**Features:**

- It can be used by moving.

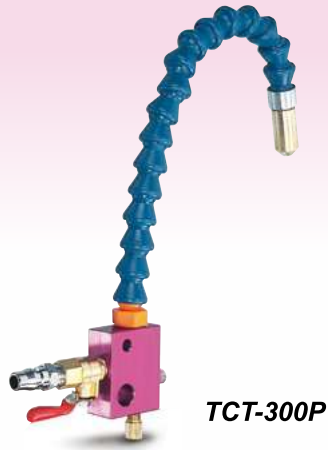

**TCT-300P**



## 規格表 Specification

型號 Model No.	淨重 N.W.	毛重 G.W.	裝箱尺寸 Shipment Size	備註 Remarks
TCT-300P	0.3 kg	0.5 kg	41x29.5x20cm	10 支 / 箱 10pcs/CTN

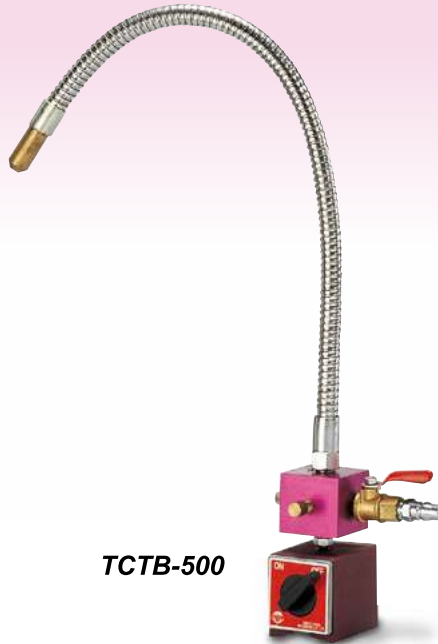

**TCTB-500**



配件  
accessories

## 規格表 Specification

型號 Model No.	淨重 N.W.	毛重 G.W.	裝箱尺寸 Shipment Size	備註 Remarks
TCTB-500	1.7 kg	1.8 kg	29x16x9cm	

# 多功能切削冷卻噴霧器

# MULTI-FUNCTION MIST COOLANT SYSTEM

## 特點：

- 使用於大型工作母機。

## Features:

- It can be used in large-size machine tool.



**TCTL-500**



**TCTL-500B**

## 規格表 Specification

型號 Model No.	淨重 N.W.	毛重 G.W.	裝箱尺寸 Shipment Size	備註 Remarks
TCTL-500	0.8 kg	1.0 kg	29x16x9cm	
TCTL-500B	1.9 kg	2.0 kg	29x16x9cm	

# 筒夾放置架 COLLET RACK

## 適用範圍：

- C32 筒夾、5C 筒夾、EOC25、ER40 筒夾。
- 可固定於機械或其他地點上。
- 適用於銑床、刀具研磨機 ... 等。

## Applications:

- Suited for colleting as C32, 5C, EOC25 and ER40.
- It can be fitted on machine or any location.
- Suited for use on milling machine, tool grinder...etc.



## 規格表 Specification

型號 Model No.	適用 Suit For	淨重 N.W.	毛重 G.W.	裝箱尺寸 Shipment Size	備註 Remarks
CR-32	C32, 5C, EOC25, ER40	0.18 kg	0.2 kg	41x29.5x20cm	12 個 / 箱 12pcs/CTN

# 工件定位器 WORK STOP TOOL

## 特點：

- 可快速、準確、重複選擇使用，並且可做多點定位。
- 可鎖在各種普遍型機械上。
- 操作簡易，可任意變化高低與方向。
- 附扳手。

## Features:

- Quick, accurate and repeated use. Set-up on many positions.
- It can be locked in general machinery.
- Operate easily and arbitrarily in adjusting height and direction.
- Attach with spanner.



定位器應用  
Typical Application



## 規格表 Specification

型號 Model No.	適用 Suit For	淨重 N.W.	毛重 G.W.	裝箱尺寸 Shipment Size	備註 Remarks
AMS-160A	各種機型 All Machine Models	0.8 kg	0.96 kg	41x29.5x20cm	
AMS-160AH		0.9 kg	1.06 kg	41x29.5x20cm	
AMS-160B		0.62 kg	0.78 kg	41x29.5x20cm	
AMS-160BH		0.72 kg	0.88 kg	41x29.5x20cm	

※AMS: Adjustable Milling Stop

# 空油壓床 HYDRAULIC PRESS MACHINE

## 特點：

- 多功能空油壓床。
- 搬運方便。
- 不佔空間。
- 結構簡化，故障率低。

## Features:

- A multi-function air oil pressure press.
- Easy to move.
- Does not occupy space.
- Simplified construction, low failure rate.



單位：mm  
unit: mm

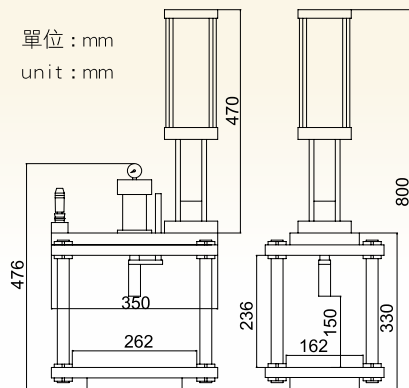

## 規格表 Specification

使用壓力 Working pressure(kg/cm <sup>2</sup> )	出力 Force output(kg)
4	1078
5	1470
6	1865
7	2050

AOP-50

## 使用範例 Applications

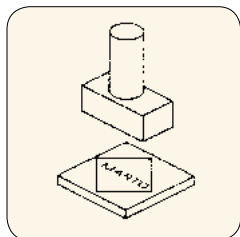

印字 Mark

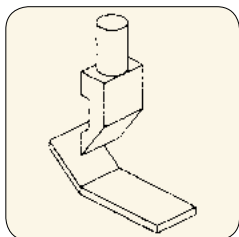

折彎 Bend

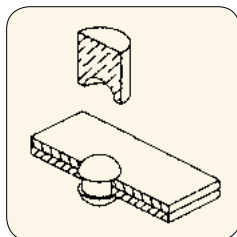

鉚合 River

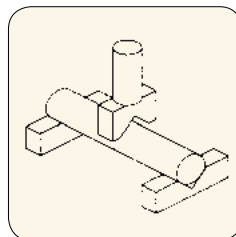

壓直，壓彎 Straighten

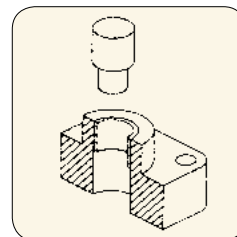

壓入 Assemble

## 規格表 Specification

型號 Model No.	最大工作高度 Max. working height(mm)	工作台面尺寸 Table sizes(mm)	操作壓力 Working pressure(kg)	快速行程 Rapid traverse(mm)	增壓行程 Boosting troke(mm)	工作頻率(次/分) Working frequency(times/min)
AOP-50	200	350x250	4~7	200	50	18

# 強力型換刀裝置 AIR POWER DRAWBAR / ELECTRIC POWER DRAWBAR

## 特點：

- 更換刀具僅須 3 秒，為傳統更換刀具速度 10 倍以上，可提高生產力，增加利潤。
- 無需敲打拉桿可保主軸之精密，並延長主軸軸承之使用壽命。
- 本機使用時，主軸無須換於低速檔或固定主軸，可於空檔使用，安全性高。
- 本機可裝置於 NC 銑床及一般 NT40# & NT50# 銑床及龍門銑床、臥式搪銑床使用。

## Features:

- It will increase your productivity with more profits as cutter replacement needs only 3 sec and the speed of replacement is more than 10 times to compare with traditional cutter replacement.
- No need to knock the top end of drawbar for loosening cutter to remain the precision of main spindle and prolong the life of bearing.
- Cutter will not rotate if the spindle was located on the neutral position.
- It fits to conventional Milling machine, NC Milling machine, plano mill and boring machine with spindle taper NT40# and NT50#.



- 適合中型銑床，經濟效益佳。
- 全氣壓式，無需外接電力，適用 NT40#.NT30# 之銑床。
- The unit is ideal for use on medium duty milling machine at economically priced.
- Fully air operated, it requires no assistance of additional electric driving. It fits to NT40#, NT40# milling machine.

## APD-230



- 二段離合器設計，主軸不迴轉。
- 全電動，不須外接動力，可空檔換刀，確保操作者安全，適用 NT40#. NT50# 之銑床使用。
- Double clutch designed to avoid the spindle running.
- Fully electric operated. It requires no assistance of additional power.
- Tool change may be performed while this power drawbar is set at neutral position, and the operator safety is fully guaranteed. It fits to NT#40, NT#50 milling machine. electric driving. It fits to NT40#, NT40# milling machine.

## EPD-240



- 大扭力，適用大型工作母機。
- 全氣壓式，無需外接電力，適用 NT50# 型之機種。
- High torque performance enabling it ideal for heavy machine tools.
- Fully air operated it requires no assistance of additional electric driving. It fits to NT50# milling machine.

## APD-700



## APD-700V



## 氣動拉桿 Air power drawbar



- |            |                                   |
|------------|-----------------------------------|
| 1. 主機      | 1.Power head with bracket         |
| 2. 護蓋      | 2.Cover of power head             |
| 3. 控制器     | 3.Control box                     |
| 4. 拉桿      | 4. Draw bar                       |
| 5. 清潔棒     | 5.Taper Wiper                     |
| 6. 三點組合濾水器 | 6. Filter of three point combined |

## 氣動拉桿 Air power drawbar



- |        |                                 |
|--------|---------------------------------|
| 1. 主機  | 1.Power head with bracket       |
| 2. 護蓋  | 2.Cover of power head           |
| 3. 電控箱 | 3.Electric control box          |
| 4. 拉桿  | 4.Draw bar (Hard chrome plated) |
| 5. 清潔棒 | 5.Taper Wiper                   |

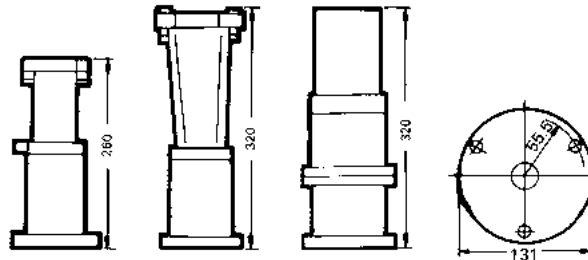

APD-230  
APD-280

APD-700  
APD-700V

EPD-240

### 規格表 Specification

型號 Model No.	適用機種 Suit for	最大扭力 Max torque	迴轉速 Running Speed	氣壓 Air pressure	淨重 N.W.	毛重 G.W.	裝箱尺寸 Shipment Size	備註 Remarks
APD-700	NT50#	700ft/lbs/950N-M	5000R.P.M.	90psi~115psi/6.3~8kg/cm2	13.6kg	15.1kg	67x42x19cm	1.89 材
APD-700V	NT50#	700ft/lbs/950N-M	5000R.P.M.	90psi~115psi/6.3~8kg/cm2	13.6kg	15.1kg	67x42x19cm	1.89 材
APD-230	NT40# NT30#	230ft/lbs/312N-M	7000R.P.M.	90psi/6.3kg/cm2	9.9 kg	11.4kg	67x42x19cm	1.89 材

### 規格表 Specification

型號 Model No.	適用機種 Suit for	最大扭力 Max torque	迴轉速 Running Speed	氣壓 Air pressure	電流量 Amps.	淨重 N.W.	毛重 G.W.	裝箱尺寸 Shipment Size
EPD-240	NT50#, NT40#	240ft/ 1bs	2100 R.P.M.	220V 50/60Hz	7.5A	11.2kg	12.7kg	67x42x19cm

## 擋屑板 UNIVERSAL CHIP-SHIELDS

### 特點：

- 萬向支臂，可固定於任何角度，使用方便迅速。在進行金屬加工時，可擋住及防止金屬屑片射出。
- 致傷及工作者身體，達到保護作用。
- 附有一文件夾，可挾持工作圖，一舉數得。

### Features:

- Universal arm, can be up any positions easily.
- Forfend metal chip shoot out while a metal cutting process on the machine, achieve as a protection of worker.
- With a file, can be clip working drawing, convenient for metal cutting processes.

### 適用範圍：

- 適用於金屬加工之操作，如銑床，鑽床，車床.....等金屬加工機。

### Features:

- Suitable for metal cutting processes on machines, such as milling machine, drilling machine, lathe machine,.....etc metal cutting machinery.



### 規格表 Specification

型號 Model No.	淨重 N.W.	淨重 N.W.	毛重 G.W.	裝箱尺寸 Shipment Size	備註 Remarks
UAM-400	400x300	1.8 kg	2.3 kg	39.5x33x9cm	

## 工業用 吸塵、吸水機 INDUSTRIAL WET / DRY VACUUM CLEANERS



JS-101



JS-150



JS-151

### 規格表 Specification

型號 Model No.	消耗電力 Consumption Power	馬力 Watts	真空壓 Vacuum	風量 Air Flow	容量 Capacity	噪音比 Noisy	電壓 Voltage	重量 Weight
JS-101	1200W	2 .5HP	2500mmVS	2.5m <sup>3</sup> /min	10 加侖 (10 gallon)	70 DBA	110/ 220V 60Hz	24kg
JS-150 單桶	2700W	5 HP	2500mmVS	5m <sup>3</sup> /min	15 加侖 (15 gallon)	70 DBA	110/ 220V 60Hz	32kg
JS-151 單桶	2700W	5 HP	2500mmVS	5m <sup>3</sup> /min	30 加侖 (30 gallon)	70 DBA	110/ 220V 60Hz	44kg

# 工作台自動進給器

# POWER TABLE FEEDS



HS-500(X)



HS-500(Y)



HS-500(Z)

## 規格表 Specification

型號 Model No.	電壓 Voltage	扭力 Torque	變速 Driving	速度範圍 Speed range	重量 Weight
HS - 500(X)	115V 50/60Hz	130 LB - IN	Variable speed	5~800 R.P.M. (7~1000 m/m)	6.5 kg
HS - 500(Y)	115V 50/60Hz	130 LB - IN	Variable speed	5~800 R.P.M. (7~1000 m/m)	6.5 kg
HS - 500(Z)	115V 50/60Hz	130 LB - IN	Variable speed	5~800 R.P.M. (7~1000 m/m)	6.5 kg

# 伺服器工作台自動進給器

# SERVO POWER TABLE FEEDS

### 特點：

- 低速運轉，扭力大。
- 故障率低。
- 適合工作台之縱向驅動（X 軸）。
- 適合 1/2# 銑床。
- 進給速度快，扭力大。

### Features:

- Low running speed. High torque output.
- Minimum failure rate.
- Applicable for table longitudinal drive(X-axis).
- For mounting on #1 1/2 milling machine.
- High Speed feed. High torque output.

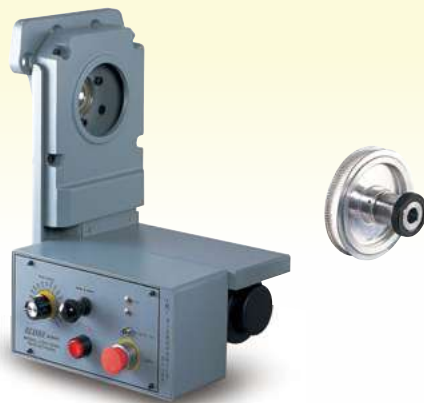

## 規格表 Specification

型號 Model No.	電壓 Voltage	扭力 Torque	變速 Driving	速度範圍 Speed range	重量 Weight
EP - 80S	110V 50/60Hz	150 kg/m	Variable speed	0~1800 R.P.M.	10 kg

# 攜帶型放電加工機 PORTABLE E.D.M.



## 規格表 Specification

電控箱 Generator	外觀尺寸	Dimensions(mm)	500 x 300 x 220
	重量	Weight(kg)	22
主機 Machine Unit	外觀尺寸	Dimensions(mm)	270 x 85 x 600
	重量	Weight(kg)	7.5
工作頭行程 Workhead Travel			100mm
電極夾頭 Maximun Current Output			10A Min *1.0mm / Max *6.3mm
電極材料 Electrode Diameter	具中心孔之黃銅棒		Brass or Copper Electrode Tube
工作液 Material of Electrode	自來水		Clean Water
輸入電源 Dielectric	AC110V or AC220V 單相電源		AC110 or AC220V, a-Phase 50/60Hz
去除牙攻尺寸 Generator Power Input			M2 ~ M12

# 攜帶型放電加工機 PORTABLE E.D.M.

## 特點：

- 快速去除斷裂牙攻與鑽頭。
- 可攜式設計，方便在各種環境下使用。
- 主機可以任意旋轉角度加工，不受限工件大小或形狀。採用放電原理消耗刀具，非接觸加工，不會損傷工件。內置高壓幫浦，利用電極中心出水提高放電效率。

## Features:

- Remove taps easily without damage to threads.
- The portable design and magnetic base, allows quick clamping on top of workpiece for easy machining even for large workpieces.
- It is self-contained unit, complete with dielectric pump and central cooling for electrode holder.
- Simple and user-friendly operating panel on controller.

## 適用範圍：

- 孔徑非要求高精度之工件。
- 可在各種大小，形狀的工件加工。

## Applications:

- Starting holes for wire cut EDM with lower precision operation.
- Cutting tungsten carbide or any hardened steel.

## 加工方法 Processing Method

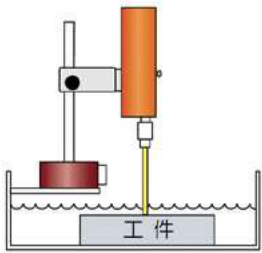

小工件  
Small workpiece

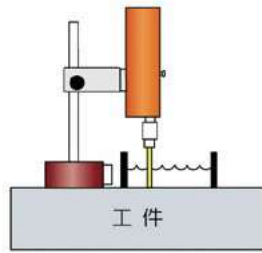

大工件  
Big workpiece

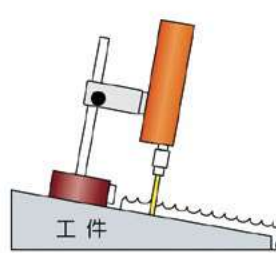

非垂直 & 不規則工件  
Non-Vertical & irregular workpiece

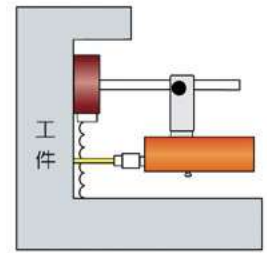

橫向加工  
Cross machining

## 去除斷裂牙攻方式 Features and Functions

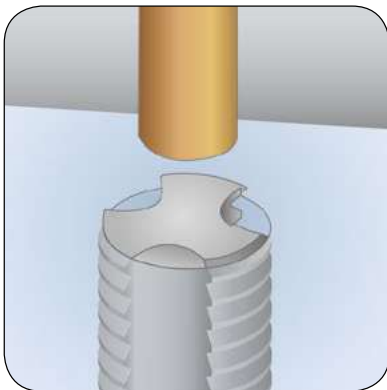

以斷裂牙攻一半直徑之銅管對準牙攻中心  
Drilling in tap center.

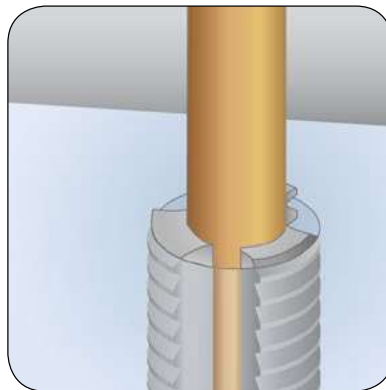

利用放電方式將牙攻中心熔化同時以高壓水柱將熔屑沖開。  
High pressure water to flush the residues.

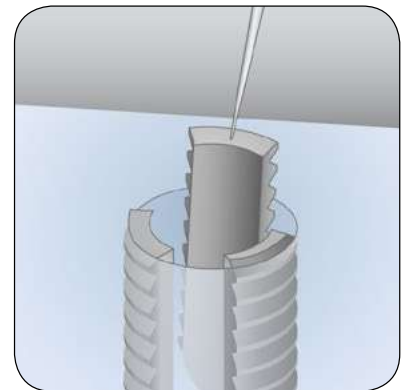

以細針將牙攻碎片及斷片挑出即去除斷裂之牙攻且不損傷螺紋。  
Top removal by needle to protect screw threads.



**宗伯實業有限公司**  
**TORNG INDUSTRIAL CO., LTD.**

43547 台中市梧棲區草湳里自立四街 25 號  
No. 25, Tzu Li 4st., Wu Chi. Taichung 43547 Taiwan  
TEL: 886-4-2639-2878  
FAX: 886-4-2639-2955  
Email: [tbltd@ms31.hinet.net](mailto:tbltd@ms31.hinet.net)  
<http://www.torng.com.tw>

本公司保有更改顏色之權利  
We reserve the right to change colors

大陸銷售聯絡方式  
QQ : 770978797